

Development and Validation of Bengali Television Serial Addiction Scale

Praiti Chakraborty^{1*}, Priyankar Singha², Subrata Dasgupta³

ABSTRACT

The study explores the factor structure and other psychometric properties of the Bengali television serial addiction scale. The sample was collected from 245 females and 55 male serial viewers from Kolkata and its peripheries. 26 items were finalised with the help of experts. Then the final scale was administered and four major factors were revealed by principal component analysis. All four factors derived were found to be reliable. The final scale consists of 18 items after removing the items having cross loadings. Construct validity and concurrent validity were established. Different measures like item-total, inter-item correlation strengthened the foundation of reliability and validity of the scale. The confirmatory factor analysis demonstrated good model fit, with all items loading significantly on their respective factors. Composite reliability values exceeded recommended thresholds, and average variance extracted supported convergent validity. Discriminant validity was also established, confirming the distinctiveness of the factors. The full scale was found to possess satisfactory reliability. The gender difference in the total test score was assessed and found to be significant. The age difference in the total score was also assessed and found to be significant. The other details are discussed herein.

Keywords: *Bengali Television Serial Watching Scale, Factor Structure, Psychometry*

Television remains a primary medium for both entertainment and information. In order to reduce the apathy of mundane life, we often indulge ourselves in certain types of TV shows. Unlike films, which typically resolve their narrative in one sitting, serials deliver stories chronologically across multiple episodes. This structure intentionally delays the climax to build curiosity and anticipation, encouraging viewers to tune into subsequent installments- a cycle that can potentially lead to addictive behavior.

Addiction is “ a state in which a person is unable to abandon a habit despite his/her tendency to give up” (ogel,2001, p/4 as cited in Karakaya,2016). Beyond chemical dependencies, the term ‘addiction’ encompasses excessive involvement in certain behaviors” (Shaffer,1999). Behavioral addictions without chemical substances include

¹Ph.D. Research Scholar, Department of Applied Psychology, University of Calcutta, Lecturer, Department of Psychology, S.A Jaipuria College, West Bengal, India

²Assistant Professor, Department of Applied Psychology, University of Calcutta, West Bengal, India

³Professor, Department of Applied Psychology, University of Calcutta, West Bengal, India

*Corresponding Author

Received: March 17, 2026; Revision Received: March 27, 2026; Accepted: March 31, 2026

Development and Validation of Bengali Television Serial Addiction Scale

activities such as watching television, gaming, overuse of mobile phones and excessive social media use (Griffiths, 1995, p.14-19). Specifically, excessive serial viewing involves an inability to inhibit the impulse to watch multiple episodes, often leading to multiple cognitive and behavioral issues. This is closely related to “Binge-watching”, which is defined as viewing three or more episodes in a single setting. (Caramella et al,2014; Horvath et al.,2017). While these media behaviors may initially be goal directed, environmental cues and a lack of self-control can eventually turn them into problematic, repetitive habits (Duhigg, 2012; LaRose, 2010). Deficit in self-control gives rise to problematic behavior. For example, decreased productivity, lack of attention. Deficient self-control often permits automatic cognitive systems to dictate behavior (LaRose et al,2003). This pattern of intense, consecutive viewing is associated with sedentary lifestyles, maladaptive behaviors, social isolation and elevated levels of anxiety and depression (Wheeler et al., 2015). Research indicates that a high propensity for binge-watching is correlated with increased depression and impulsivity- a construct that shares significant parallels with serial addiction (Forte et al.,2021). Early clinical observations by Meerloo (1954) proposed that television addiction is a tangible phenomenon, acting as “food for the senses” that can lead to generalized apathy, neglect of responsibilities, negativism. And an over-reliance on fantasy. Consequently, regular viewers of television serials may struggle with impulse control, a drive for immediate gratification, and persistent apathy. While serial viewing may serve as a “social lubricant” for some, it can manifest as a source of addiction for others. While many engage with serials for entertainment, for some, the behavior evolves into a dependence or compulsion. Television serial viewing may thus be defined as an urge or a difficulty in inhibiting the impulse- to watch multiple episodes of one or more series. The present study seeks to identify the underlying motives behind serial-watching behavior and distinguish addicted viewers from non-addicts. Furthermore, it aims to elucidate the maladaptive behaviors and psychological vulnerabilities present in individuals experiencing serial addiction.

The Bengali/Tollywood TV industry stands as one of the most prominent media sectors in India, boasting a vast audience that spans the entire country. The serial was introduced to its viewers in 1975. Since then, the medium has evolved into a cornerstone of the region’s social and cultural fabric. In Kolkata and its surrounding areas, the evening ritual is largely defined by families gathering to watch and anticipate for the latest episodes of their favorite serials. Some of the contemporary Bangla serials which are worth mentioning, i.e., ‘Mithai’ and ‘Pilu’, ‘Jogoddhatri’, ‘Fulki’ and ‘Chirosakha’. They are quite popular having BARC (TRP) ratings ranging from 4.9 to 6.1. Despite their popularity, the narrative content of many Bengali serials frequently relies on dogmatic beliefs, superstitions and gender stereotypes, polygamous relations. Most of them revolves around the theme of same sex relationship, unwed motherhood, polygamy. This deep level of engagement is reflected in the active social media communities where viewers “watch and criticize” the daily soaps, often viewing the content as more negative than positive, yet remaining unable to disconnect from it (Anitha,2014). Apart from Bengali serials, there are multiple television serial viewers across the nation in different languages e.g. Hindi, Marathi, Punjabi. However, there is no standardized scale available for measuring the addiction towards serial watching in either of the language.

The Present Study

This study aims to develop and evaluate the factor structure and to determine its reliability, validity and other psychometric properties within the Indian population, specifically in West

Development and Validation of Bengali Television Serial Addiction Scale

Bengal. This research will provide a formal framework for future administration, facilitating the study of serial addiction across diverse groups in India.

METHOD

For the purpose of development and validation of the of BTSAS scale and to determine its factor structure and other psychometric properties, it was administered to both men and women. For this purpose, 300 sample consisting of 245 females and 55 males were administered the scale. The participants are from Kolkata and its outskirts. Multistage stratified random sampling was employed for this study. The entire sample was geographically categorised into north, south, central Kolkata. From each zone the sample was again divided into male and female. A list of participants was prepared with the help of concerned corporations and municipalities. Only willing participants were included in the study. Another inclusion criteria was that the participant has to be a regular viewer of Bengali serials. The mean age of the participant was 37.473 and the range of age was 20-65 years.

Measure

An information schedule was prepared and used for the demographical information. Then the Bengali Television serial scale was administered to participants. The scale utilizes a five-point Likert-type scale, where the score ranges from 1 (strongly agree) to 5 (strongly disagree). Higher scores in the scale indicate greater inclination towards serial addiction. There are four factors in the test: i) dependency (Dependency refers to compulsive watching and inability to control the behaviour related to household, sleep and occupation.) ii) Anticipation (Anticipation refers to cues related to the content of the television serial) iii) Underperformance (Underperformance refers to a significant inability to keep up with all major life responsibilities related to academics, career or social life) iv) craving (Craving entails the extent of pleasure and mood during watching). The Cronbach's alpha of the subscales ranged from 0.69 to .82. The Cronbach alpha for the entire test was found to be highly reliable ($\alpha=.886$). thus, the factors with their respective items as well as the full scale were found to be internally consistent.

Procedure

Data was collected from Bengali serial viewers of different age and gender residing in and out Kolkata. The responses were properly scored and tabulated. initially, t tests are conducted between the top and bottom 27% scores on each item to determine if the items differentiated extreme groups. The items having significant t values were then subjected to item-total correlation using Pearson 'r' statistic (Patton et al.,1995). The items who have met the criteria were subjected to principal component analysis (PCA), followed by exploratory factor analysis (EFA). Following Exposito et al., the EFA was conducted using the Promax rotation method, which comes under one of the oblique rotation methods. After the factors and loadings were derived after conducting the factor rotation, the Confirmatory factor analysis (CFA) was administered to assess its accuracy. Using CFA, the reliability and validity of each of the derived factors were also determined. This step consists of conduction of inter-factor correlation. An inter-factor correlation has been to make the reliability and validity analysis even stronger. Finally, t test was employed to determine the gender differences in the total scores. The norms and Cronbach's alpha were also found out for the scale. The statistical data analyses and visualizations were done in IBM SPSS v25 and R studio.

RESULTS

The table shows the descriptive statistics of the BTSAS items. The item-total correlation indicates that all the items correlate significantly with the total scores of BTSAS. All the items, correlate highly significantly with the total ($p < 0.001$).

Table 1: Mean, Median, skewness, SD, Item-total correlation of each item

Item	Max	Min	Mean	Median	SD	Skew	Item Total Correlation
I1	5	1	2.1967	2	1.2205	0.93	.501**
I2	5	1	1.8	1	1.1003	1.45	.575**
I3	5	1	2.2367	2	1.1995	0.787	.556**
I4	5	1	2.4433	2	1.3661	0.524	.527**
I5	5	1	1.6733	1	0.9502	1.731	.542**
I6	5	1	1.9833	2	1.2005	1.141	.498**
I7	5	1	1.9233	2	1.1699	1.247	.597**
I8	5	1	1.4967	1	0.8199	2.192	.439**
I9	5	1	1.75	1	1.1366	1.466	.394**
I10	5	1	1.58	1	0.9486	1.922	.559**
I11	5	1	1.73	1	1.0135	1.493	.610**
I12	5	1	1.5933	1	0.9474	1.796	.609**
I13	5	1	1.8233	1	1.1119	1.354	.620**
I14	5	1	2.2433	2	1.2896	0.772	.658**
I15	5	1	1.9633	2	1.1945	1.126	.550**
I16	5	1	2.77	3	1.478	0.095	.532**
I17	5	1	2.9333	3	1.3546	-0.065	.506**
I18	5	1	2.0067	2	1.2376	1.085	.494**
I19	5	1	1.8167	1	1.1463	1.437	.688**
I20	5	1	2.8933	3	1.4819	0.011	.627**
I21	5	1	1.95	2	1.2244	1.251	.730**
I22	5	1	1.9567	2	1.2137	1.247	.673**
I23	5	1	1.62	1	0.9995	1.892	.604**
I24	5	1	2.91	2.5	2.6188	11.191	0.514*
I25	5	1	2.1567	2	1.2372	0.809	.652**
I26	5	1	2.6733	3	1.3685	0.204	.640**

* $p < 0.05$, ** $p < 0.001$

The above table shows the descriptive statistics of the BTSAS items. The mean responses to several items of BTSAS are found to be 2.5. The skewness of items is found to be satisfactory. All the items fall within the skewness cut off of -2 to +2 (Field,2009; Gravetter and Wallnau,2014; Trochim & Donnelly,2006). The item-total correlation indicates that all the items correlate positively and significantly with the total scores of BTSAS at 99% level of confidence.

Table 2: test of discrimination of BTSAS items

Items	<i>t</i>	<i>p</i>
I1	35.6**	0.000
I2	18.451**	0.000
I3	40.853**	0.000
I4	63.625**	0.000

Development and Validation of Bengali Television Serial Addiction Scale

Items	<i>t</i>	<i>p</i>
I5	15.57**	0.000
I6	25.48**	0.000
I7	21.616**	0.000
I8	14.774**	0.000
I9	19.606**	0.000
I10	15.614**	0.000
I11	18.228**	0.000
I12	17.147**	0.000
I13	20.063**	0.000
I14	40.38**	0.000
I15	26.457**	0.000
I16	62.725**	0.000
I17	43.107**	0.000
I18	27.709**	0.000
I19	19.17**	0.000
I20	61.411**	0.000
I21	22.07**	0.000
I22	22.183**	0.000
I23	15.853**	0.000
I24	41.448**	0.000
I25	36.77**	0.000
I26	62.116**	0.000

** $p < 0.001$

Table 1 already indicated the maximum and the minimum values of the items and it was found to be the same for all the items (5 and 1, respectively). The above table shows the t-test for the upper and lower 27% scores (N=81 each), which was found to be highly significant for all the items ($p < 0.001$). Thus, the adequate discriminatory power of the items of BTSAS has been established. These items can be now proceeded for further analyses. The figure below depicts the mean scores of the upper and lower scores for each item.

Table 3: Descriptive Statistics and t-test of the BTSAS items across gender

Items	Gender	N	M	SD	<i>t</i>	df	<i>p</i>
I1	Male	55	4.345	0.480	33.340**	113.497	0.000
	Female	245	1.714	0.707			
I2	Male	55	3.800	0.826	21.216**	62.366	0.000
	Female	245	1.351	0.478			
I3	Male	55	4.273	0.449	32.142**	132.916	0.000
	Female	245	1.780	0.758			
I4	Male	55	4.473	0.504	26.076**	173.162	0.000
	Female	245	1.988	1.046			
I5	Male	55	3.182	1.073	12.496**	58.785	0.000
	Female	245	1.335	0.473			
I6	Male	55	2.727	1.027	10.691**	58.025	0.000
	Female	245	1.220	0.415			
I7	Male	55	3.509	0.858	18.224**	61.505	0.000
	Female	245	1.331	0.471			

Development and Validation of Bengali Television Serial Addiction Scale

Items	Gender	N	M	SD	t	df	p
I8	Male	55	3.218	0.937	15.407**	58.976	0.000
	Female	245	1.229	0.421			
I9	Male	55	4.400	0.494	30.905**	133.528	0.000
	Female	245	1.759	0.837			
I10	Male	55	4.109	0.629	28.042**	79.706	0.000
	Female	245	1.482	0.625			
I11	Male	55	4.745	0.440	24.350**	247.079	0.000
	Female	245	2.327	1.248			
I12	Male	55	4.673	0.474	21.688**	213.891	0.000
	Female	245	2.543	1.168			
I13	Male	55	3.945	0.756	24.485**	64.232	0.000
	Female	245	1.339	0.483			
I14	Male	55	4.909	0.290	27.840**	297.634	0.000
	Female	245	2.441	1.245			
I15	Male	55	4.218	0.658	28.981**	73.039	0.000
	Female	245	1.441	0.567			
I16	Male	55	4.182	0.696	27.022**	71.457	0.000
	Female	245	1.457	0.575			
I17	Male	55	3.309	1.069	14.093**	57.946	0.000
	Female	245	1.241	0.428			
I18	Male	55	4.291	0.458	33.313**	129.451	0.000
	Female	245	1.678	0.756			

** $p < 0.001$

The above table shows the demographic statistics for all the items of BTSAS. The t-test was conducted to determine the gender differences in the responses of each of the items and it was noted that gender differences were prevalent with males scoring higher on each of items ($p < 0.001$).

Fig. 1: Means of upper and lower category scores of BTSAS items

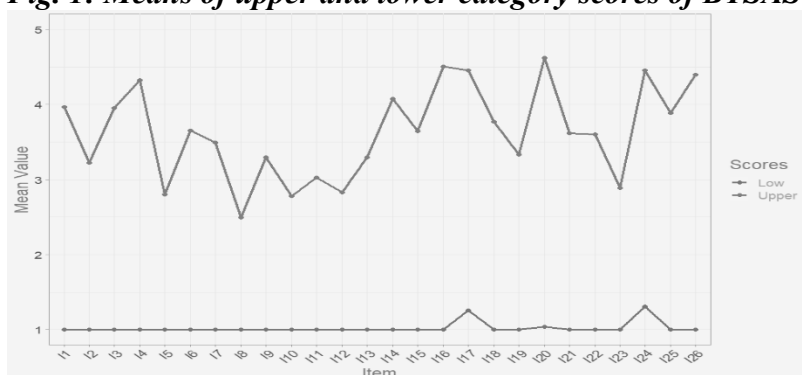

Factor Analysis

Table 4: Diagnostic statistics of Principal Component Analysis of BTSAS

Diagnostic Statistics	Value
KMO	0.902
Bartlett's Test of Sphericity	1838.035**

** $p < 0.000$

Development and Validation of Bengali Television Serial Addiction Scale

In the above table, the KMO value has been found to 0.902, which is above the cutoff of 0.8, implying good sampling adequacy. The Bartlett's χ^2 was also found to be highly significant ($p < 0.000$), concurring with the norms of nullifying the current model to fit with identity matrix. Both the criteria is set by Silva et al. (2014). The model correlation coefficient was also found to yield highly significant values ($p < 0.000$), rendering the model fit for factor rotation.

Fig. 2: The Scree Plot

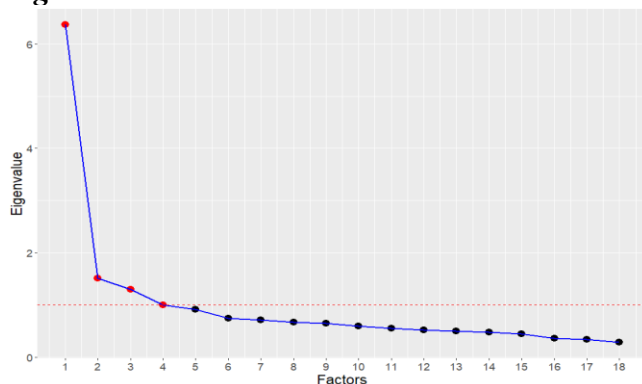

Table 5: The EFA estimates of BTSAS

Items	Factors				h ²
	1	2	3	4	
I21	0.855				0.636
I23	0.848				0.652
I19	0.699				0.562
I22	0.639				0.387
I12	0.622				0.567
I20	0.511				0.663
I16		0.806			0.623
I15		0.711			0.568
I4		0.594			0.477
I25		0.560			0.571
I17		0.539			0.541
I14		0.510			0.366
I8			0.845		0.594
I11			0.641		0.544
I5			0.638		0.723
I1				0.820	0.540
I2				0.771	0.671
I3				0.697	0.497
% variance explained	35.356	8.397	7.213	5.594	
Cronbach's α	0.825	0.743	0.71	0.696	

The Exploratory Factor Analysis (EFA) was conducted using Promax rotation technique following Expósito et al. (2014). The original Promax model, using all the original 26 items of BTSAS, showed discrepancies in terms of the factor analysis norms. The cutoff scores for communalities (h²) is usually taken as 0.4 and that for the factor loadings is 0.5. following

Development and Validation of Bengali Television Serial Addiction Scale

Hulland (1999) and Truong and McColl (2011). Though these cutoffs were met, some of the items in original factor structure violated cross-loading norms (Costello & Osborne, 2019). Hence, one grounds of cross loading across multiple factors and/or low reliability, the following eight items: I6, I7, I9, I10, I13, I18, I24 and I26 were removed.

The new model with the remaining 18 items was factor-analysed again with Promax rotation technique and the various model criteria (as mentioned above) were met. The rotated correlation matrix showed correlation of above ± 0.32 (criteria set by Tabachnick & Fidell, 2007), which served as a rationale for retaining Promax as a rotation technique. The table above shows the yielded factors with no cross-loading items. The scree plot above shows the four yielded factors having eigenvalue of above 1.0. The current model shows satisfactory factor loadings of all items. Factor 1 includes items I21, I23, I19, I22, I12 and I20; factor 2 is composed by items I16, I15, I4, I25, I17 and I14. While factor 3 includes items I8, I11 and I5, the items I1, I2 and I3 are included in the fourth factor. The PCA triplot is shown in figure below. The h^2 shows deviation from the norms of 0.4 in case of items 14 and 22, however, the deviation being negligible, the items were retained in the model. The factors 1 to 4 explained approximately 35%, 8%, 7% and 6% of the variance. The total model R^2 was found to be 56.56, implying satisfactory variance-explained by the model. The Cronbach's α for each of the four models surpassed the criteria of 0.6 (Hulin et al., 2001). The full-scale Cronbach's α , inclusive of the 4 factors was found to be 0.886. Thus, the factors with their respective items as well as the full scale were found to be internally consistent.

Thus, the validity of the BTASAS scale has been established with 18 working items spread across four major factors or components as shown in the table above.

Fig. 3: The PCA triplot of BTSAS

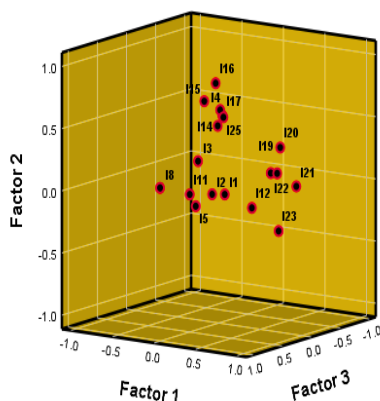

Table 6: Concurrent Validity of BTSAS

	<i>r</i>	<i>p</i>
<i>BTSAS vs. BWS</i>	0.939**	0.000

** $p < 0.001$

Binge watching Addiction questionnaire (BWAQ) has been used as a criterion to determine the concurrent validity of BTSAS scale. Binge watching questionnaire serves the ground for the selection as a criterion and a well validated psychometric tool with a sound psychometric property, ($\alpha=0.89$). BWAQ has a good convergent, construct and criterion related validity. The correlation between both the scales is found to be highly significant and positive ($r=0.93$) at 99% level of confidence.

Development and Validation of Bengali Television Serial Addiction Scale

Fig. 4: The CFA model

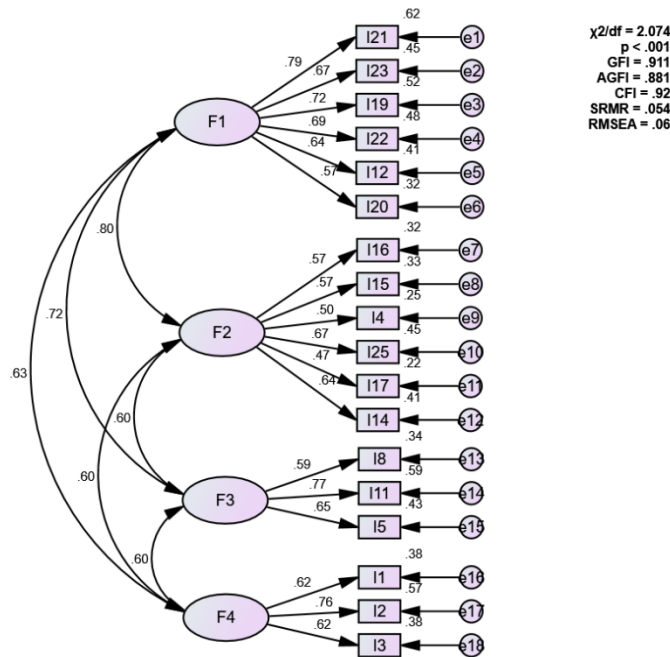

Table 7: The SEM model estimates

Paths	β	b	SE	CR	p
I21 ← F1	0.787	1 [#]			
I23 ← F1	0.67	0.695	0.06	11.622	0.000**
I19 ← F1	0.718	0.855	0.068	12.574	0.000**
I22 ← F1	0.691	0.871	0.072	12.034	0.000**
I12 ← F1	0.638	0.628	0.057	10.997	0.000**
I20 ← F1	0.566	0.871	0.09	9.628	0.000**
I16 ← F2	0.568	1 [#]			
I15 ← F2	0.575	0.818	0.109	7.505	0.000**
I4 ← F2	0.502	0.817	0.12	6.812	0.000**
I25 ← F2	0.672	0.989	0.119	8.294	0.000**
I17 ← F2	0.474	0.765	0.117	6.518	0.000**
I14 ← F2	0.641	0.985	0.122	8.065	0.000**
I8 ← F3	0.587	1 [#]			
I11 ← F3	0.768	1.617	0.187	8.661	0.000**
I5 ← F3	0.654	1.29	0.16	8.086	0.000**
I1 ← F4	0.619	1 [#]			
I2 ← F4	0.756	1.102	0.128	8.579	0.000**
I3 ← F4	0.619	0.983	0.125	7.887	0.000**

Note: ** $p < 0.001$ #Reference Category

The CFA model met the recommended thresholds for goodness-of-fit indices: $\chi^2/df \leq 5$, $p \geq .01$, $GFI \geq .95$, $AGFI \geq .90$, $CFI \geq .90$, $SRMR \leq .08$, and $RMSEA \leq .08$, in line with the guidelines proposed by Hu and Bentler (2009) and Schermelleh-Engel et al. (2003) (Figure 1). All factor loadings were statistically significant ($p < .001$), with each item loading appropriately onto its designated factor (Table 1). Based on these standardized estimates, further computations were carried out, as presented below.

Development and Validation of Bengali Television Serial Addiction Scale

Table 8: The CFA estimates

Factors	AVE	CR	Inter-Factor Correlations			
			F1	F2	F3	F4
F1	0.654	0.808	0.809			
F2	0.632	0.798	0.796	0.795		
F3	0.565	0.730	0.725	0.601	0.752	
F4	0.546	0.710	0.632	0.597	0.598	0.734

Note: Square root of AVE across the diagonals (boldfaced). All inter-factor correlations are significant ($p < .01$)

The composite reliability (CR) values for all four factors exceeded the recommended threshold of 0.70 (Fornell & Larcker, 1981), ranging from 0.710 to 0.808, thus demonstrating satisfactory internal consistency (Table 2). These findings align with the Cronbach's α reported earlier, indicating stable reliability across the constructs.

Convergent validity was established, as the average variance extracted (AVE) values for all factors were above the minimum cutoff of 0.50 (Hair et al., 2006). In addition, the significant factor loadings presented in the SEM model further confirmed the presence of convergent validity.

The square roots of AVE (presented on the diagonals in bold) were greater than the inter-factor correlations for all the factors, providing evidence for discriminant validity (Henseler et al., 2015; Kline, 2011). This suggests that the four constructs are empirically distinct from each other. One inter-factor correlation (e.g., between F1 and F2, $r = .796$) approached the root AVE values but still remained within acceptable limits. Therefore, the factors were retained as theoretically and statistically distinguishable.

The inter-factor correlations have been illustrated below in table 3. It can be found that the inter-items correlations are found to be highly significant ($p < 0.000$), further strengthening the evidence of satisfactory reliability and convergent validity of the scale. Positive and average correlation is noted among the items across the factors.

Table 9: The inter- item correlations

Items	I12	I19	I20	I21	I22	I23	I4	I14	I15	I16	I17	I25	I5	I8	I11	I1	I2	I3	
I12																			
I19	.482**																		
I20	.260**	.435**																	
I21	.406**	.556**	.424**																
I22	.489**	.412**	.314**																
I23	.590**	.572**	.397**																
I4				.284**	.295**	.301**	.251**	.337**											
I14				.399**	.379**	.295**	.362**												
I15				.357**	.286**	.371**													
I16				.260**	.442**														
I17					.316**														
I25																			
I5									.415**	.467**									
I8										.476**									
I11																			
I1																	.495**	.359**	
I2																		.454**	
I3																			

**p < 0.000

Gender Differences

Table 10: t-test for the variables

Variables	Gender	N	M	SD	Range	t	Cronbach's (α)
BTSAS	Male	55	32.727	11.984	18-78		
	Female	245	38.539	12.410	18-78		
Total Test		300	37.47	12.51	18-78	-3.229**	0.886

**p < 0.01

As shown in table 6, there is a significant difference between the total test scores obtained by men and women. The women are found to have higher score mean than mean which is indicative of stronger inclination towards serial viewing behaviour. The mean of total scores for the entire sample size was found to be 37.47, with an SD of 12.51. The total sample test had a Cronbach's (α) of 0.886, indicating high reliability.

Table 11: One-way ANOVA for the age groups

Variable	Source	SS	df	MS	F	p	Tukey's Post Hoc	1 vs 3	2 vs 3
BTSAS	between	1156.925	2	578.462	3.760*	0.024	n.s.	*	n.s.
	within	45691.86	297	153.845					

**p< 0.01 *p< 0.05 n.s.= not significant 1= 20-35 years 2=36-50 years 3= 51-65 years

The one-way ANOVA was conducted to determine differences across the three age groups on the variables (table 9). Significant age group differences were observed for BTSAS [$F(2, 297) = 3.76, p < .05$]. however, the multi group comparison showed significant age difference between group 1 and 2.

DISCUSSION

The factor structure and other psychometric properties of BTSAS were found out for the population of West Bengal. The sample comprises 345 females and 55 males. All participants are residents of Kolkata and its outskirts. All participants fall under the inclusion criteria of being a Bengali serial viewer. The t-test among the top and bottom responses for each item and the item-total correlation gives an indication of possessing a sound internal consistency among the items. Total four factors were derived with the help of PCA and EFA. Then factors were rotated obliquely using the Promax rotation technique. After that, items are allotted to respective factors based on the factor loadings. 8 items have been removed due to the violation of cross-loading norms, (Costello & Osborn,2019). Hence the final scale results in 18 items with four factors.

The reliability of each of the four factors were found out in this study which indicates high internal consistency. Together the four factors were found to explain 56% of variance in the present study. The construct validity was found out using exploratory factor analysis. The concurrent validity of the scale was found out and it depicts a high positive correlation with the criterion, Binge watching addiction questionnaire (Forte et al., 2021).

Confirmatory factor analysis (CFA) findings from the present study are in strong alignment with similar psychometric investigations on behavioral addiction scales. For instance, the Problematic Series Watching Scale demonstrated excellent model fit indices (CFI = 0.998; RMSEA = 0.024), confirming a unidimensional structure with high reliability ($\omega = 0.79$), which parallels the strong factor loadings and fit indices found in the BTSAS (Fino et al., 2022). Similarly, the Binge-Watching Addiction Questionnaire (BWAQ) confirmed a four-factor structure—Craving, Dependency, Anticipation, and Avoidance—with robust psychometric support, echoing the multidimensionality captured in the BTSAS (Forte et al., 2021).

Scales designed for social media addiction also show comparable CFA outcomes. The Social Media Addiction Scale-Student Form (SMA-SF) demonstrated a four-factor structure accounting for over 50% of the variance, with high internal consistency ($\alpha = .93$) and CR values consistent with the BTSAS estimates (Şahin, 2018). Further, cross-cultural adaptations—such as the Romanian validation of the SMA-SF—confirmed the same four-factor model with good CFA fit indices (CFI = 0.916; RMSEA = 0.062), demonstrating replicability of factor structures across contexts (Ursoniu et al., 2022). Likewise, the Chilean validation of the Social Media Addiction Scale (SMAS) yielded a two-factor model with

Development and Validation of Bengali Television Serial Addiction Scale

good reliability ($\alpha = .841$) and excellent fit ($CFI = .959$, $RMSEA = .060$), again consistent with the satisfactory psychometric benchmarks observed in the BTSAS (Martínez-Libano et al., 2023).

More recent adaptations extend to YouTube addiction, where the Turkish version of the YouTube Addiction Scale confirmed a unidimensional CFA model with acceptable internal consistency and strong concurrent validity, again showing parallels with BTSAS's stable construct validity (Dinç et al., 2025). Similarly, the Chinese Social Media Addiction Scale identified six factors with Cronbach's alpha of 0.937 and demonstrated excellent CFA fit, reinforcing the multidimensional nature of media addictions (Liu & Ma, 2018).

Additionally, the item-total correlation conducted as initial steps which deemed valid for use and provided good content validity of the test. The inter-factor correlation and inter-item correlation were computed and were found to be highly significant ($p < .01$). Both these measures made the reliability statement even stronger. The gender difference in the mean scores of BTSAS was found to be significant, thus aligning with the findings of Problematic series watching scale Fino et al., (2022).

Limitations and final scope

The study also possesses some limitations. In spite of being statistically adequate, the sample was not large enough. The discrepancies between the measures could be reduced if the sample taken was larger. Thus, we could expect perfect values for standardization. The scale consists of 18 items enabling a quick measure of serial addiction. Further studies should be done to find out its possible comorbidity with other behavioural addiction. The study is only centred on Bengali speaking population who are very fond of watching serials or who consider this as their daily rituals. Hence it does not include the entire serial viewers population of other languages and cultures. Another pitfall could be lack of availability of the other scales for comparison. Further studies should be done in other languages or in different cultures to validate this construct.

CONCLUSION

Despite the limitations, the results indicate that the BTSAS scale has adequate psychometric properties which may help researchers to understand the various facets of addictive serial watching behaviour. One of the advantages of this scale is that it can discriminate people having pathological serial viewing from those who indulge in it solely for entertainment. It gives us an idea to what extent this particular behaviour is considered as normal. Hence it provides us with a continuum from non-pathological or normal to pathological watching. It might prove helpful to understand the risk factors associated with it, its contribution in mental health condition and proposing intervention strategies for the same.

REFERENCES

- Anitha, K. (2014). Socio, economic and Cultural impact of soap operas on home makers (A study in Andhra Pradesh). *Journal of Mass Communication & Journalism*, 4(4), 189. <https://doi.org/10.4172/2165-7912.1000189>
- Caramella, D.; Biscuiti M. *Can't stop, Won't stop: Binge-Viewing is Our New Favorite Addiction*; Miner: New York, NY, USA, 2014.
- Costello, A.B., & Osborne, J. (2019). Best Practices in Exploratory factor analysis: Four recommendations for getting the most from your analysis. *Practical assessment, Research, and Evaluation*, 10(7). <https://doi.org/10.7275/jyj1-4868>

Development and Validation of Bengali Television Serial Addiction Scale

- Dinç, E., Ruckwongpatr, K., Karaduman, A., Chen, I. H., Karaduman, A., & Wang, X. L. (2025). YouTube addiction scale (YAS): Adaptation to Turkish culture, validity and reliability study. *Journal of Social Media Research*. <https://doi.org/10.29329/jsomer.20>
- Duhigg, C. (2012). *The Power of habit: Why We Do What We Do in Life and business*. Random House, 2012.
- Exposito, E., Olmedo-Moreno, E.M., & pegalajar, M.C. (2014). Factorial analysis of the burnout syndrome in a sample of Spanish teachers. *Procedia- social and behavioral sciences*, 132, 393-398. [Hhttps://doi.org/10.1016/j.sbspro.2014.04.327](https://doi.org/10.1016/j.sbspro.2014.04.327)
- Field, A. (2009). *Discovering statistics using spss* (3rd ed.) SAGE Publications.
- Fino, E., Humphries, M., Robertson, J., Orosz, G., & Griffiths, M. (2022). Factor structure, reliability and criterion-related validity of the English version of the Problematic Series Watching Scale. *BJPsych Open*, 8(1), e27. <https://doi.org/10.1192/bjo.2022.561>
- Fornell, C., & Larcker, D. F. (1981). Evaluating structural equation models with unobservable variables and measurement error. *Journal of Marketing Research*, 18(1), 39-50.
- Forte, G., Favieri, F., Tedeschi, D., & Casagrande, M. (2021). Binge-watching: Development and validation of the Binge-Watching Addiction Questionnaire. *Behavioral Sciences*, 11(2), 27. <https://doi.org/10.3390/bs11020027>
- Gravetter, F.J., & Wallnau, L.B. (2014). *Essentials of statistics for the behavioral sciences* (8th ed.). Cengage Learning.
- Griffiths, M., & Wood, R.T. (2000). Risk factors in adolescence: The case of gambling, videogame playing, and the Internet. *Journal of Gambling studies*, 16 (2-3), 199-225
- Hair, J. F., Black, W. C., Babin, B. J., Anderson, R. E., & Tatham, R. L. (2006). *Multivariate data analysis* (6th ed.). Pearson University Press.
- Henseler, J., Ringle, C.M., & Sarstedt, M. (2015). A new criterion for assessing discriminant validity in variance-based structural equation modelling. *Journal of the Academy of Marketing Science*, 43(1), 115-135. <https://doi.org/10.1007/s11747-014-0403-8>
- Horvath, J. C.; Horton, A.J.; Lodge, J.M.; Hattie, J.A. The impact of binge watching on memory and perceived comprehension. *First Monday* 2017,22, doi: 10.5210/fm.v22i9.7729.
- Hulland, J. (1999). Use of partial least squares (PLS) in strategic management research: A review of four recent studies. *Strategic Management Journal*, 20(2), 195-204. [https://doi.org/10.1002/\(SICI\)1097-0266\(199902\)20:2<195::AID-SMJ37>3.0.CO;2-7](https://doi.org/10.1002/(SICI)1097-0266(199902)20:2<195::AID-SMJ37>3.0.CO;2-7)
- Hulin, C., Netemeyer, R., & Cudeck, R. (2001). Can a reliability coefficient be too high? *Journal of consumer Psychology*, 10(1/2), 55-58 https://doi.org/10.1207/S15327663JCP1001&2_05
- Hu, L. T., & Bentler, P. M. (1999). Cutoff criteria for fit indexes in covariance structure analysis: Conventional criteria versus new alternatives. *Structural equation modeling : a multidisciplinary journal*, 6(1), 1-55. <https://doi.org/10.1080/10705519909540118>
- Kline, R. B. (2011). *Principles and Practice of Structural Equation Modeling* (3rd ed.). Guilford.
- LaRose, R. (2010). The Problem of Habit. *Communication Theory*, 20(2), 194-222.
- Liu, C., & Ma, J. (2018). Development and validation of the Chinese social media addiction scale. *Personality and Individual Differences*, 134, 55–59. <https://doi.org/10.1016/j.paid.2018.05.046>
- Martínez-Líbano, J., González-Campusano, N., Pereira Castillo, J., Oyanedel, J., & Yeomans-Cabrera, M. (2023). Psychometric properties of the Social Media

Development and Validation of Bengali Television Serial Addiction Scale

- Addiction Scale (SMAS) on Chilean university students. *Data and Metadata*. <https://doi.org/10.56294/dm202391>
- Meerlo, J. (1954). Television addiction and reactive apathy. *Journal of Nervous and Mental Disease*, 120, 290-291.
- Ogel, K. (2012). Internet Bagimhhgi, Internetin psikolojisini anlamak ve bagimhhkla basa cikmak. (s.47-60). *Istanbul: Turkiye Is Bankasi kultur Yayinlari*.
- Patton, J.H., Stanford, M.S., & Barratt, E.S. (1995). Factor structure of the Barratt Impulsiveness Scale. *Journal of Clinical psychology*, 51(6), 768-774. [https://doi.org/10.1022/1097-4679\(199511\)51:6<768::AID-JCLP2270510607>3.0.CO;2-1](https://doi.org/10.1022/1097-4679(199511)51:6<768::AID-JCLP2270510607>3.0.CO;2-1)
- Şahin, C. (2018). Social Media Addiction Scale-Student Form: The reliability and validity study. *Turkish Online Journal of Educational Technology*, 17(1), 169–182.
- Shaffer, D. W., & Kaput, J. J. (1999). *Educational Researcher*, 33(9), 14-25.14.
- Schermelleh-Engel, K., Moosbrugger, H., & Muller, H. (2003). Evaluating the fit of structural equation models: Tests of significance and descriptive goodness of fit measures. *Methods of Psychological Research Online*, 8(2), 23-74.
- Tabachnick, B.G., & Fidell, L.S. (2007). *Using multivariate statistics (5th ed.)*. Allyn & bacon/ Pearson Education.
- Trochim, W.M., & Donnelly, J.P. (2006). *The research methods knowledge base (3rd ed.)*. Atomic Dog publishing
- Truong, Y., McColl, R. (2011). Intrinsic motivations, self-esteem, and Luxury consumption. *Psychology & marketing*, 28(11), 1091-1102. <https://doi.org/10.1002/mar.20431>
- Ursoniu, S., Şerban, C., Giurgi-Onucu, C., Riviş, I., Bucur, A., Papavă, I., & Bredicean, A. (2022). Validation of the Romanian version of the Social Media Addiction Scale-Student Form (SMAS-SF) among undergraduate medical students. *Neuropsychiatric Disease and Treatment*, 18, 1195–1205. <https://doi.org/10.2147/NDT.S368476>
- Wheeler, K.S. The Relationships between Television Viewing Behaviors, Attachment, Loneliness, Depression and Psychological Well-Being. *Ph.D. Thesis, Georgia Southern University, Statesboro, GA, USA, 2015, 98*.
- Dadhania, D.A. (2015). Mental Health and Psychological Well-Being in Adolescence Boys and Girls. *International Journal of Public Mental Health and Neurosciences*, Vol. 2 (3), pp. 10-12.

Acknowledgment

The author(s) appreciates all those who participated in the study and helped to facilitate the research process.

Conflict of Interest

The author(s) declared no conflict of interest.

How to cite this article: Chakraborty, P., Singha, P. & Dasgupta, S. (2026). Development and Validation of Bengali Television Serial Addiction Scale. *International Journal of Indian Psychology*, 14(1), 2599-2619. DIP:18.01.259.20261401, DOI:10.25215/1401.259

Development and Validation of Bengali Television Serial Addiction Scale

Appendix A1. Bengali Television Serial Addiction Scale. The English translation is shown in parentheses.

		একেবারেই অসম্মত (1)	অসম্মত (2)	সিদ্ধান্ত নেওয়া যাচ্ছে না (3) Neutral	সম্মত (4)	একেবারেই সম্মত (5)
		Strongly Disagree	Disagree	Neutral	Agree	Strongly Agree
1.	আমি অনেক বেশি সময় ধরে টেলিভিশন সিরিয়াল দেখি। (I spend too much time in watching television serials.)					
2.	আমি মনে করি যে আমার জীবন টেলিভিশন সিরিয়াল ছাড়া ফিকে হয়ে যাবে। (I feel my life would become dull without television serials.)					
3.	আমার কাছে সিরিয়াল দেখা অন্য যে কোনো কিছুর চেয়ে আনন্দদায়ক। (I derive pleasure out of watching serials than anything else.)					
4.	আমি প্রায়ই টেলিভিশন সিরিয়াল সম্বন্ধে পর্যালোচনা ও মতামত পড়ি। (I often read reviews and opinions about Television serials)					
5.	টেলিভিশন সিরিয়াল দেখার জন্য আমি ঘরের কাজ অবহেলা করি। (I found myself neglecting household chores for watching television serials.)					
6.	আমি সিরিয়াল দেখতে গিয়ে প্রায়ই খাবার খাই না। (I often skip a meal while watching serials.)					
7.	সিরিয়াল দেখার জন্য আমি অন্যান্য উপভোগের জিনিস উপেক্ষা করি। (I often ignore other					

Development and Validation of Bengali Television Serial Addiction Scale

	enjoyments for the sake of serial watching.)					
8.	সিরিয়াল দেখার সময় আমার নিজেকে পৃথিবী থেকে বিচ্ছিন্ন মনে হয়। (I imagine myself outside the real world while watching serials.)					
9.	আমি যখন সিরিয়াল দেখি, আমি যা ভাবি তার চেয়ে বেশি সময় কাটিয়ে ফেলি। (I spend more time on watching television serials than planned.)					
10.	টেলিভিশন সিরিয়াল দেখা আমার পারিবারিক সম্পর্কগুলিকে প্রভাবিত করে। (Television serial watching affects my family relationships.)					
11.	একটি টিভি সিরিয়ালের পরবর্তী পর্বগুলিতে যা যা ঘটতে পারে সেই পটভূমি নিয়ে আমি কল্পনা করি। (I fantasize about the plots which would unfold in the subsequent episodes of a TV serial.)					
12.	মানসিক চাপ থেকে মুক্ত হতে আমি নিজেকে টিভি সিরিয়াল দেখায় নিয়োজিত করি। (I do indulge myself in watching TV serials to release my tension.)					
13.	অন্যদের সঙ্গে ঘুরতে যাওয়ার চেয়ে আমি সিরিয়াল দেখে সময় কাটাতে বেশি পছন্দ করি। (I like to spend my time watching serials than hanging out with others.)					
14.	আমি অবসর পেলেই সিরিয়াল দেখি। (I engage all my leisure time in watching serials.)					

Development and Validation of Bengali Television Serial Addiction Scale

15.	আমি সিরিয়াল দেখতে না পারলে আমার নিজেকে অস্থির লাগে। (I find myself becoming restless and jittery if I refrain from watching serials.)					
16.	সিরিয়াল দেখার সময় কেউ বাধা দিলে আমি তার সঙ্গে রুচ ব্যবহার করি। (I misbehave when somebody bothers me while watching a television serial.)					
17.	সিরিয়াল দেখা আমার জীবনের সবচেয়ে গুরুত্বপূর্ণ কাজ বলে আমি মনে করি। (I feel serial watching is the most important activity in my life.)					
18.	টেলিভিশন সিরিয়ালের বিষয়বস্তু নিয়ে আমার ভাবনায় মগ্ন থাকার প্রবণতা আছে । (I tend to be preoccupied with the contents of the serials.)					

Table 1: Mean, Median, Skewness, SD, Item-total correlation of each item

Item	Max	Min	Mean	Median	SD	Skew	Item Total Correlation
I1	5	1	2.1967	2	1.2205	0.93	.501**
I2	5	1	1.8	1	1.1003	1.45	.575**
I3	5	1	2.2367	2	1.1995	0.787	.556**
I4	5	1	2.4433	2	1.3661	0.524	.527**
I5	5	1	1.6733	1	0.9502	1.731	.542**
I6	5	1	1.9833	2	1.2005	1.141	.498**
I7	5	1	1.9233	2	1.1699	1.247	.597**
I8	5	1	1.4967	1	0.8199	2.192	.439**
I9	5	1	1.75	1	1.1366	1.466	.394**
I10	5	1	1.58	1	0.9486	1.922	.559**
I11	5	1	1.73	1	1.0135	1.493	.610**
I12	5	1	1.5933	1	0.9474	1.796	.609**
I13	5	1	1.8233	1	1.1119	1.354	.620**
I14	5	1	2.2433	2	1.2896	0.772	.658**
I15	5	1	1.9633	2	1.1945	1.126	.550**
I16	5	1	2.77	3	1.478	0.095	.532**
I17	5	1	2.9333	3	1.3546	-0.065	.506**
I18	5	1	2.0067	2	1.2376	1.085	.494**
I19	5	1	1.8167	1	1.1463	1.437	.688**
I20	5	1	2.8933	3	1.4819	0.011	.627**
I21	5	1	1.95	2	1.2244	1.251	.730**
I22	5	1	1.9567	2	1.2137	1.247	.673**

Development and Validation of Bengali Television Serial Addiction Scale

I23	5	1	1.62	1	0.9995	1.892	.604**
I24	5	1	2.91	2.5	2.6188	11.191	0.514*
I25	5	1	2.1567	2	1.2372	0.809	.652**
I26	5	1	2.6733	3	1.3685	0.204	.640**

*p<0.05, **p< 0.001

Table 2: Descriptive Statistics and t-test of the BTSAS items across gender

Items	Gender	N	M	SD	t	df	p
I1	Male	55	4.345	0.480	33.340**	113.497	0.000
	Female	245	1.714	0.707			
I2	Male	55	3.800	0.826	21.216**	62.366	0.000
	Female	245	1.351	0.478			
I3	Male	55	4.273	0.449	32.142**	132.916	0.000
	Female	245	1.780	0.758			
I4	Male	55	4.473	0.504	26.076**	173.162	0.000
	Female	245	1.988	1.046			
I5	Male	55	3.182	1.073	12.496**	58.785	0.000
	Female	245	1.335	0.473			
I6	Male	55	2.727	1.027	10.691**	58.025	0.000
	Female	245	1.220	0.415			
I7	Male	55	3.509	0.858	18.224**	61.505	0.000
	Female	245	1.331	0.471			
I8	Male	55	3.218	0.937	15.407**	58.976	0.000
	Female	245	1.229	0.421			
I9	Male	55	4.400	0.494	30.905**	133.528	0.000
	Female	245	1.759	0.837			
I10	Male	55	4.109	0.629	28.042**	79.706	0.000
	Female	245	1.482	0.625			
I11	Male	55	4.745	0.440	24.350**	247.079	0.000
	Female	245	2.327	1.248			
I12	Male	55	4.673	0.474	21.688**	213.891	0.000
	Female	245	2.543	1.168			
I13	Male	55	3.945	0.756	24.485**	64.232	0.000
	Female	245	1.339	0.483			
I14	Male	55	4.909	0.290	27.840**	297.634	0.000
	Female	245	2.441	1.245			
I15	Male	55	4.218	0.658	28.981**	73.039	0.000
	Female	245	1.441	0.567			
I16	Male	55	4.182	0.696	27.022**	71.457	0.000
	Female	245	1.457	0.575			
I17	Male	55	3.309	1.069	14.093**	57.946	0.000
	Female	245	1.241	0.428			
I18	Male	55	4.291	0.458	33.313**	129.451	0.000
	Female	245	1.678	0.756			

** p < 0.001

Development and Validation of Bengali Television Serial Addiction Scale

Table 3: The EFA estimates of BTSAS

Items	Factors				h ²
	1	2	3	4	
I21	0.855				0.636
I23	0.848				0.652
I19	0.699				0.562
I22	0.639				0.387
I12	0.622				0.567
I20	0.511				0.663
I16		0.806			0.623
I15		0.711			0.568
I4		0.594			0.477
I25		0.560			0.571
I17		0.539			0.541
I14		0.510			0.366
I8			0.845		0.594
I11			0.641		0.544
I5			0.638		0.723
I1				0.820	0.540
I2				0.771	0.671
I3				0.697	0.497
% variance explained	35.356	8.397	7.213	5.594	
Cronbach's α	0.825	0.743	0.71	0.696	

Table 4: The SEM model estimates

Paths	β	b	SE	CR	p
I21 ← F1	0.787	1 [#]			
I23 ← F1	0.67	0.695	0.06	11.622	0.000**
I19 ← F1	0.718	0.855	0.068	12.574	0.000**
I22 ← F1	0.691	0.871	0.072	12.034	0.000**
I12 ← F1	0.638	0.628	0.057	10.997	0.000**
I20 ← F1	0.566	0.871	0.09	9.628	0.000**
I16 ← F2	0.568	1 [#]			
I15 ← F2	0.575	0.818	0.109	7.505	0.000**
I4 ← F2	0.502	0.817	0.12	6.812	0.000**
I25 ← F2	0.672	0.989	0.119	8.294	0.000**
I17 ← F2	0.474	0.765	0.117	6.518	0.000**
I14 ← F2	0.641	0.985	0.122	8.065	0.000**
I8 ← F3	0.587	1 [#]			
I11 ← F3	0.768	1.617	0.187	8.661	0.000**
I5 ← F3	0.654	1.29	0.16	8.086	0.000**
I1 ← F4	0.619	1 [#]			
I2 ← F4	0.756	1.102	0.128	8.579	0.000**
I3 ← F4	0.619	0.983	0.125	7.887	0.000**

Note: **p < 0.001 #Reference Category

Development and Validation of Bengali Television Serial Addiction Scale

Table 5: The CFA estimates

Factors	AVE	CR	Inter-Factor Correlations			
			F1	F2	F3	F4
F1	0.654	0.808	0.809			
F2	0.632	0.798	0.796	0.795		
F3	0.565	0.730	0.725	0.601	0.752	
F4	0.546	0.710	0.632	0.597	0.598	0.734

Note: Square root of AVE across the diagonals (boldfaced). All inter-factor correlations are significant ($p < .01$)

Table 6: The inter-item correlation

Items	I12	I19	I20	I21	I22	I23	I4	I14	I15	I16	I17	I25	I5	I18	I11	I1	I2	I3	
I12																			
I19	.482**																		
I20	.260**	.435**																	
I21	.406**	.556**	.465**																
I22	.489**	.412**	.314**																
I23	.590**	.572**	.397**																
I4	.284**	.295**	.301**	.251**	.337**														
I14	.399**	.379**	.295**	.362**															
I15	.357**	.286**	.371**																
I16	.260**	.442**																	
I17	.316**																		
I25																			
I5																			
I18																			
I11																			
I1																			
I2																			
I3																			

** $p < 0.000$